

JVC

SERVICE MANUAL

DVD PLAYER

XV-521BK/523GD XV-525BK/421BK

Supplement

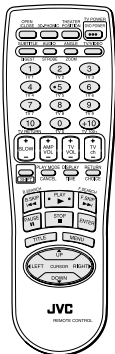

XV-521BK/XV-523GD/XV-525BK models

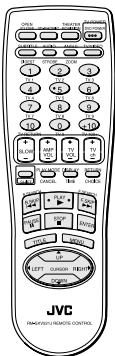
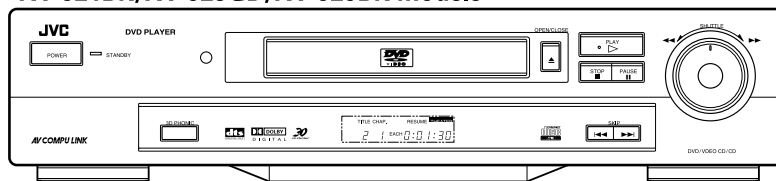

XV-421BK model

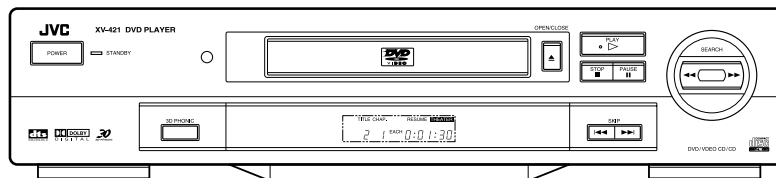

Area Suffix

XV-421BK

J U.S.A

Area Suffix

XV-525BK/523GD

J U.S.A

Area Suffix

XV-521BK

C Canada



Video CD



The following are the altered sections on the previously issued [XV-521BK/523GD/525BK/421BK] No.20836.

1. "Main adjustment" are added.
2. "Check point for each error" are added.
3. IC701 (M101C12GHA) is added on "Description of major ICs" section.

Main adjustment

Adjustment and confirmation matter

(1) Auto adjustment method

If microprocessor (IC401, IC402, IC791, IC403) or Pick-up is replaced, initialize the DVD player in the following matter:

1. Initialize the DVD player in the following matter:

- 1) Make sure that no disc is on the tray.
- 2) Insert the power pulag to the outlet while pressing "PLAY" and "OPEN/CLOSE" button at the same time.
FL Display indicate "TEST * * ¥ " (* * ;Version. ¥ ;Region code)
- 3) Press 3D-PHONIC button. And EEPROM initialize start.
- 4) When indicate "V.REPLACE" on the display , initialize finished.

* The test mode is cancelled when the power is turned off.

(2) Flap adjustment of the Pick-up guide shaft

- 1) Make sure that no disc is on the tray.
- 2) Insert the power pulag to the outlet while pressing "PLAY" and "OPEN/CLOSE" button at the same time.
FL Display indicate "TEST * * ¥ " (* * ;Version. ¥ ;Region code)
- 3) Press the "OPEN/CLOSE" button to move the tray outward.
Put the Test Disc (VT-501) on the tray and press "OPEN/CLOSE" button.
The tray should move inward (Note: Don't push to close the tray directly by hand etc.)
- 4) Press the "PLAY" button.
- 5) The laser current and the jitter value is displayed on the FL indicator as follows.

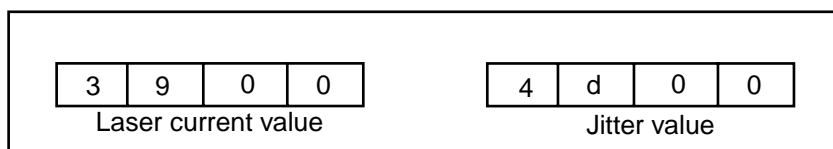

FL indicator

- 6) Set the Jitter value of FL indicator to minimum by adjusting the pick-up guide shaft flap.

* The test mode is cancelled when the power is turned off.

Flap adjustment method

Measurement	Adjustment point	Mode	Disc
FL Display	Refer to Fig.2	Reproduction part	VT-501
Measurement machine	connections	Extension cord No.	
No need	Refer to Fig.1	QUQ605-4040AJ	
General tool : Hex-head wrench(1.27mm)			

"Flap adjustment" of the Pick-up guide shaft adjusts "Tangential adjustment machine screw" A and "Tilt adjustment machine screw" B from the DVD Mechanism A'ssy bottom.

1. The part at the center on the DVD test disc is reproduced.
2. The flap adjustment screws is turned alternately and set the jitter value of FL indicator to its minimum.

Note

1. The tangential adjustment is done finish and, then, tilt is adjusted.
2. The repeat the adjustment 2-3 times, for best result.
3. The final adjustment should be tilt adjustment.

Confirmation after adjustment.

Confirm to reproduce video CD and CD after the DVD test disc is adjusted and to find abnormality.

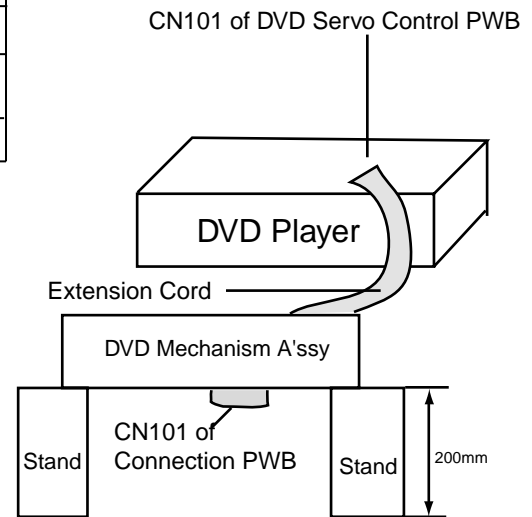

Fig.1

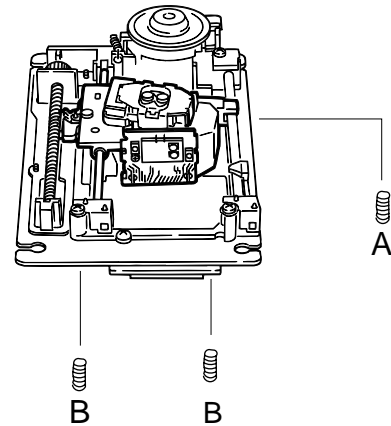

Fig.2

(3) About keeping the disc

As for the DVD test disc, plane accuracy is demanded. Please note the keeping place on the disc.

1. Please do not put the disc directly on the work desk etc. after uses .
2. To keep the planarity of the disc, politely handle ,and please put in a special case and keep the disc vertically after uses .
Please keep keeping the disc in a cool place where direct sunshine and the air-conditioning wind do not drive.
3. When the disc curves, an accurate adjustment cannot be done.
Please exchange for a new test disc and adjust optics.
- 4 Other discs might not be able to be reproduced when adjusting on a curved disc.

Point of adjustment

- * Please execute the static electricity protection measures before starting the adjustment.
- * When the following parts are exchanged, optical adjustment "Adjust the flap of Pick-up guide shaft" is necessary.
 1. The disc motor was exchanged.
 2. The laser pick up was exchanged.
 3. The traverse motor unit was exchanged.

Note

Additionally, please adjust the flap of the disc motor when the picture quality deterioration is seen. The basic adjustment though, is unnecessary for part exchange in the traverse. An optical adjustment in the laser pick up cannot be done. Please adjust the flap of the disc motor after exchanging the laser pick up.

- * When the traverse unit is exchanged, the adjustment is basically unnecessary.

Checkpoints for individual errors

(1) Spindle startup error

1. Defective spindle motor

- * Is the resistance between CN101 "34-35" and "36-37" about 10 to 6 ohms? (Measure it with the power OFF.)
- * Is the voltage waveform for the hall element CN101"40" square-wave? (During rotation)

2. Defective spindle driver (IC271)

- * Is DC voltage applied to IC271"14-15"?
- * Is IC271"25" set to "H" (SPMUTE)?

3. Servo IC

Is control available at the motor driver?

- * IC201"52" → R290 50% duty during stop. Variable during rotation (Fluctuates especially during startup.)
- If no control available: pattern servo IC, IC201.

4. Is FG input in the servo IC?

- * IC271"42" → IC271"41" → 0275 → IC201"53" (FG) FG waveform observation
- If no FG input: pattern IC271, IC201.

(2) Disk detection, distinction error (no discs, no REFNV)

1. Defective laser

2. Defective front-end processor (IC101)

3. Defective APC circuit → Q101, Q102

4. Defective pattern

A pattern between all CN101 PIC related patterns and the IC101

5. Defective servo IC (IC201)

6. IC101

Are IC101"20"(AS), IC101"41"(RFENV), and IC101"22"(FE) included in the signal to IC201?

(3) Traverse movement error

1. Defective traverse motor

- * Is voltage applied between CN101 "38" and "39"?

2. Defective BTL driver

- * Is voltage applied on IC271 "9" and "10"?
 - * Is MUTE1 terminal "26" of IC271 set to "H"?
 - * Is drive voltage applied to servo IC201"51"?
- Defective servo IC or defective pattern

(4) Focus ON error

1. Is FE produced? → Pattern, IC101
2. Is FODRV signal produced? (R280) → Pattern, IC201
3. Is drive voltage available?
If not available: pattern, driver, or mechanism. (Turn the power OFF then measure the resistance between CN101 "30" and "31".)
4. Defective mechanism

(5) Tracking ON error

1. When tracking loop is not retracted, TE waveform does not converge.
2. Defective mechanism
The possible cause for unavailability of correct retraction is that automatic adjustment cannot be made successfully.
3. Driver and its related parts (IC271)
Constant and IC defects (When it was passed during the adjustment below without going into an abnormal condition)
4. Servo IC (IC201)
When automatic adjustment was unsuccessful due to defective ICs.

(6) Spindle CLV error

1. When the spindle servo is not locked successfully, RF eye-pattern cannot be locked successfully.
2. IC101"35" (RF OUT), IC101"30" (RF-), IC101"31"(RF+)
3. Is the driver spindle signal input not clipped by the output signal?
4. Is the transistor ON?
5. Defective spindle motor or driver.
6. Other errors may be caused by defective mechanism (jitter) etc. in IC 101 and IC201.

(7) Address Read Failure

The failure may be caused by many possible factors and it is difficult to pick one out. However, the following are among the possible causes.

1. Defective mechanism (significant jitter)
2. IC (IC201, IC301, IC401)
3. Contaminated or damaged discs.

(8) Inter-layer Jump error

1. Defective mechanism.
2. Defective constant or IC of the Driver IC (IC271).
3. Defective servo IC (IC201).

[During Normal Playback of DVD]

(9) No image or sound

1. Search is not possible.

a) Can the transistor be switched ON?

If not, see "(5) Tracking ON Error" in "Checkpoints for Individual Errors".

b) Is the feed operation normal?

In case of an error, check "(3) Traverse Movement Error" in "Checkpoints for Individual Errors" or check if there is any point where the feed mechanism is caught.

(10) Picture disturbance or unusual sound once every few seconds.

Check if the feed operation during playback is smooth.



If not, perhaps the mechanism is caught.

(11) Others (Example of special cases that occurred in the past)

1. Occasionally, the picture becomes a block or stops.
2. The condition along the innermost perimeter is OK.
However, at the outermost corner, the picture becomes a block or stops frequently.
Inaccurate tilting may also be the cause.
So, perform readjustment of mechanism tilting.

With these symptoms, it is probably a bad jitter value that is causing the problem.

[During normal CD playback]

(12) Is TOC read possible? $\xrightarrow{\text{NO}}$ Refer to the Servo flow.

CD-DA shows the total time.
V-CD changes to double-speed.

\downarrow YES

Can it play? $\xrightarrow{\text{NO}}$

1. The OSD screen shows "NO READING" message.
(9) As in the case of "Search is not possible", check the feed and tracking.
2. Time display is available, but there is no sound.
Check DAC, etc. except the Servo.
3. Time flow unstable. Picture abnormal (V-CD).
Measure the jitter.
4. Check whether the discs is contaminated or damaged.

Troubleshooting

Servo volum

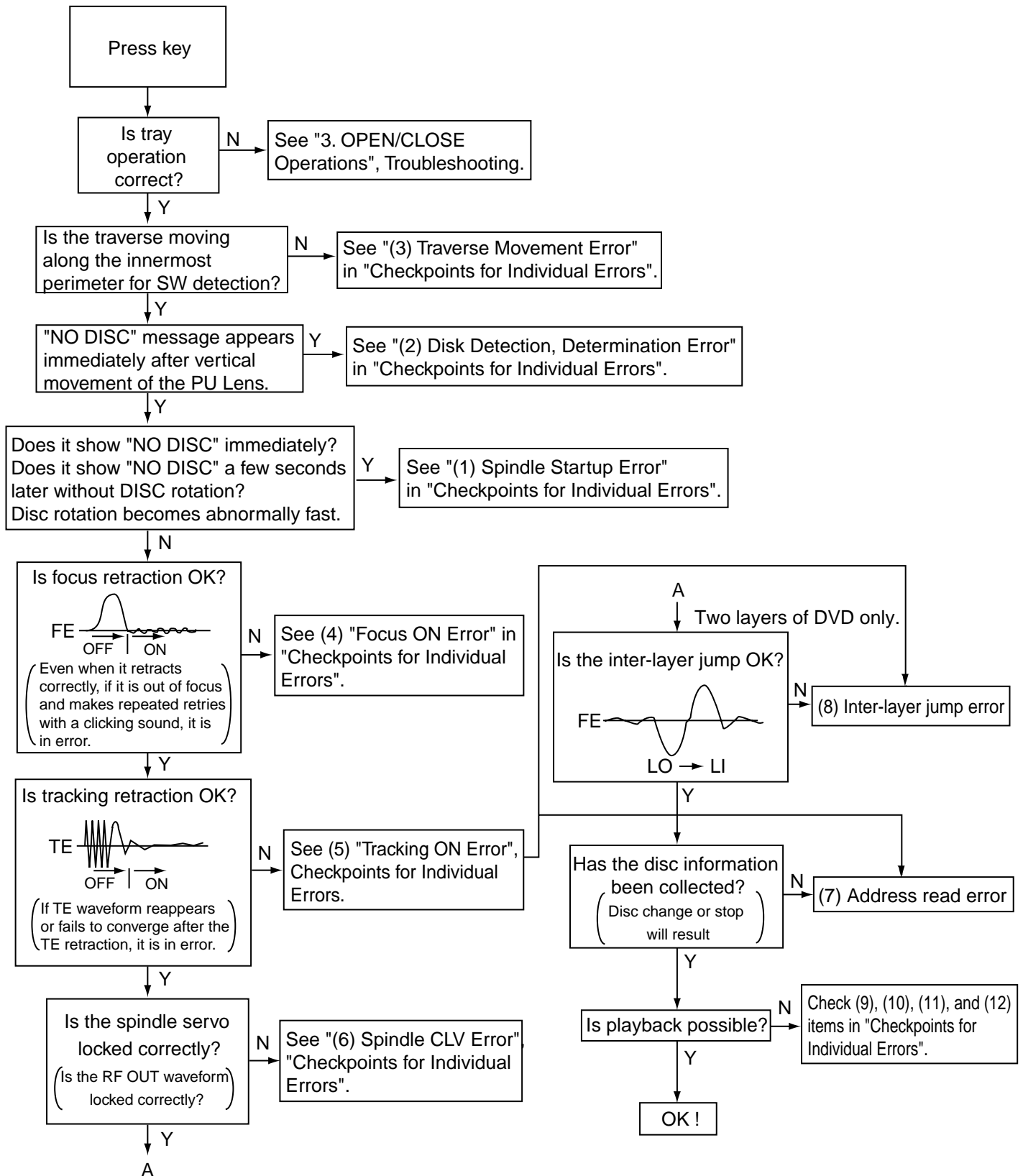

■ MN101C12GHA (IC701) : System micom

1. Terminal layout

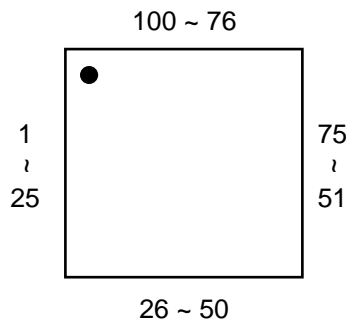

2. Pin function

Pin No.	Symbol	I/O	Function
1	GND	-	
2	CS0	I	Setup bit 0 (Effective with U/E versions) software pull-up? available.
3	CS1	I	Setup bit 1 (Effective with U/E versions) software pull-up? available.
4	CS2	I	Setup bit 2 (Effective with U/E versions) software pull-up? available.
5	NTSEL	I	NTSC/PAL Input select switch
6	POWERSW	I	Power key Input
7	SAFETEY	I	
8		I	
9		I	
10	VREF+	-	
11	VDD	-	
12	OSC2	O	10MHz
13	OSC1	I	
14	VSS	-	
15	-	I	Not used. Connect to GND
16	-	O	Not used.
17	MMOD	I	Connect to GND
18	OSDCS3	O	V. ENCODER Chip select
19	RSTE	O	V. ENCODER Reset
20	OSDDO	O	V.ENCODER Communications DATA
21	S2UDT	O	Communications DATA OUT between the Unit and the Microprocessor
22	U2SDT	I	Communications DATA IN between the Unit and the Microprocessor
23	SCLK	O	Communications CLK between the Unit and the Microprocessor
24	BUSY	O	Communications BUSY between the Unit and the Microprocessor
25	CPURST	O	Unit microprocessor Reset
26	REQ	I	Communications REQ between the Unit and the Microprocessor
27	REMO	I	Remote control interruption
28	CS3	I	Setup password change judging bit (H change, L Normally)
29		I	
30	TEST	I	H: Checker mode, L: Normal mode
31	TEST	I	
32		I	
33	RESET	I	Reset Input
34	MT0	O	Tray motor control 0
35	MT1	O	Tray motor control 1
36		O	
37	OSDCK	O	V. ENCODER Communications CK
38	NT	O	NTSC/PAL Switching (V. ENCODER)
39	FS2	O	48kHz/96kHz Switching
40	OPEN	I	Tray OPEN Switch detection Software pull-up??? available
41	CLOSE	I	Tray CLOSE Switch detection Software pull-up??? available
42		O	
43		O	
44		O	
45	FLDATA0	O	FL Driver Communications DATA 0

Pin No.	Symbol	I/O	Function
46	FLDATAI	I	FL Driver Communications DATA 1
47	FLCK	O	FL Driver Communications CLOCK
48	FLCS	O	FL Driver Communications CS
49	FLRST	O	
50	EEDO	O	EEPROM Communications DATA 0
51	EEDI	I	EEPROM Communications DATA 1
52	EECK	O	EEPROM Communications CLOCK
53	EECS	O	EEPROM Communications CS
54	VS1	O	S1 Control
55	VS3	O	S3 Control (STBY:H, P.ON:L)
56		O	
57		O	
58		O	
59		O	
60		O	
61		O	
62		O	
63	KARAOKE	O	KARAOKE Gain Control (For KARAOKE, set H)
64	POWERON	O	POWER ON OUTPUT
65		O	
66		O	
67		O	
68		O	
69		O	
70		O	
71		O	
72		O	
73		O	
74		O	
75		O	
76		O	
77	AVC1	I	AV COMPULINK INPUT
78	AVCO	O	AV COMPULINK OUTPUT
79		O	
80	STANBYIND	O	STANDBY LED OUTPUT
81		O	
82		O	
83		O	
84		O	
85		O	
86		O	
87	MA	O	DAC Control MA
88	MB	O	DAC Control MB
89	M1M3	O	DAC Control M1M3
90	MD	O	DAC Control MD
91	MC	O	DAC Control MC
92		O	
93		O	
94		O	
95	DAVSS	-	
96		O	
97		O	
98		O	
99	MUTE	O	Front Mute OUTPUT
100	DAVDD	-	

XV-521BK/523GD
XV-525BK/421BK

JVC

VICTOR COMPANY OF JAPAN, LIMITED

OPTICAL DISC BUSINESS DIV. PERSONAL & MOBILE NETWORK BUSINESS UNIT

AV & MULTIMEDIA COMPANY 1644, Shimotsuruma, Yamato, Kanagawa 242-8514, Japan